

EVACUATION SYSTEMS

Venturi-Type System for Lowline, Small Beside The Press, and Auger-Feed Granulators.

A simple, low cost system designed to convey material from a special bin to a holding receptacle located near the granulator. The system uses air flow through a specially designed venturi to draw material from the holding bin. No blower is required. A typical system would include a #2 cyclone separator.

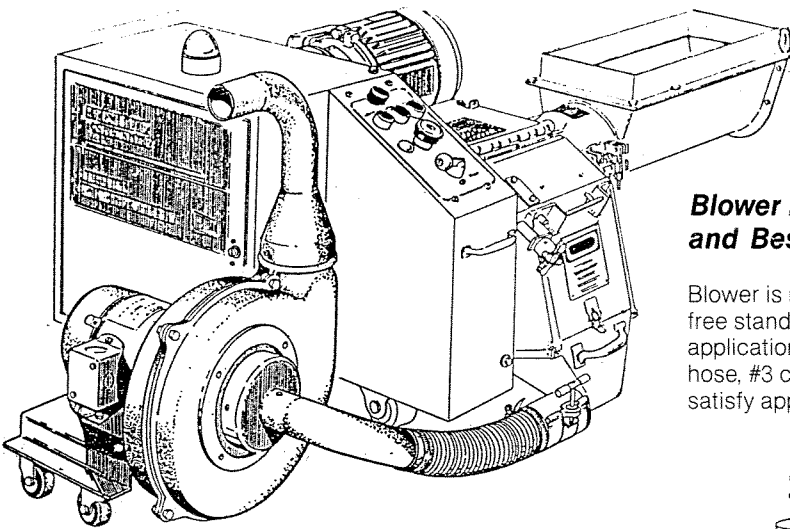
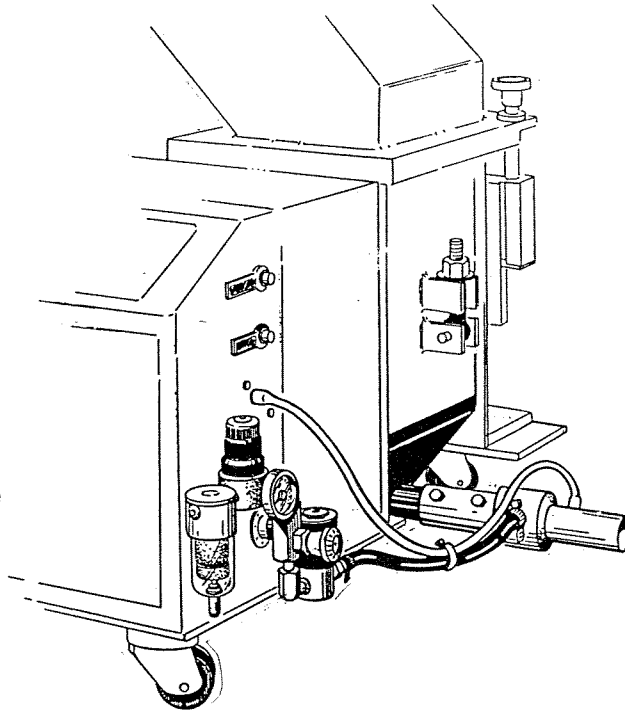

Blower Evacuation Systems for Auger Feed and Beside The Press Machines.

Blower is mounted to the machine, or can be supplied free standing on the floor (for after market or retrofit applications). Typical system: 9-10 blower, 2" I.D. flexible hose, #3 cyclone separator. Other sizes available to satisfy application requirements.

Cyclone Separators

Mounted on a tripod stand to fit over a 35" drum. Sizes available to suit all throughput requirements. Units include filter bag and automotive type after filters.

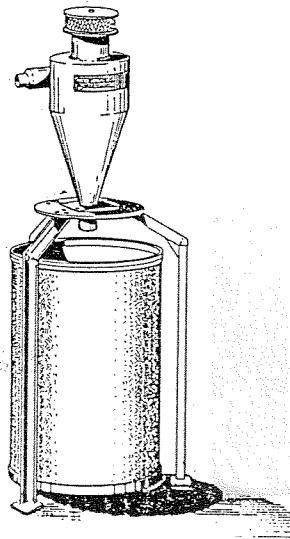

HOSOKAWA POLYMER SYSTEMS
63 Fuller Way
Berlin, GT 06037

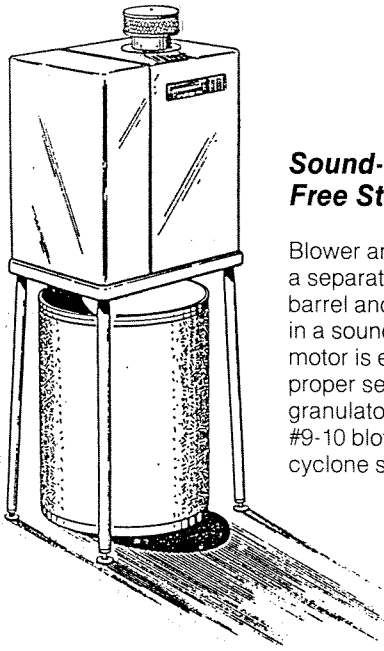

**Sound-Enclosed
Free Standing Systems.**

Blower and cyclone are mounted on a separate stand to fit over a 35" barrel and are completely contained in a soundproof enclosure. Blower motor is electrically interlocked for proper sequence of starting blower, granulator and auger. Typical system; #9-10 blower, 2" I.D. flexible hose, #3 cyclone separator.

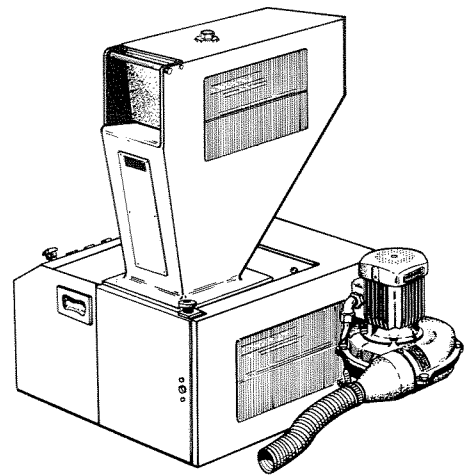

**Machine Mounted Evacuation
Systems For Lowline Granulators.**

Space-saving units with #8 or #9 blower. #2 or #3 cyclone separator.

**Evacuation Systems for Shurfeed®
and Central Granulators.**

Model 1621 and 1627 Shurfeed granulators, and Model 1526 and Model 2040 central granulators can be equipped with systems for high volume material recovery.

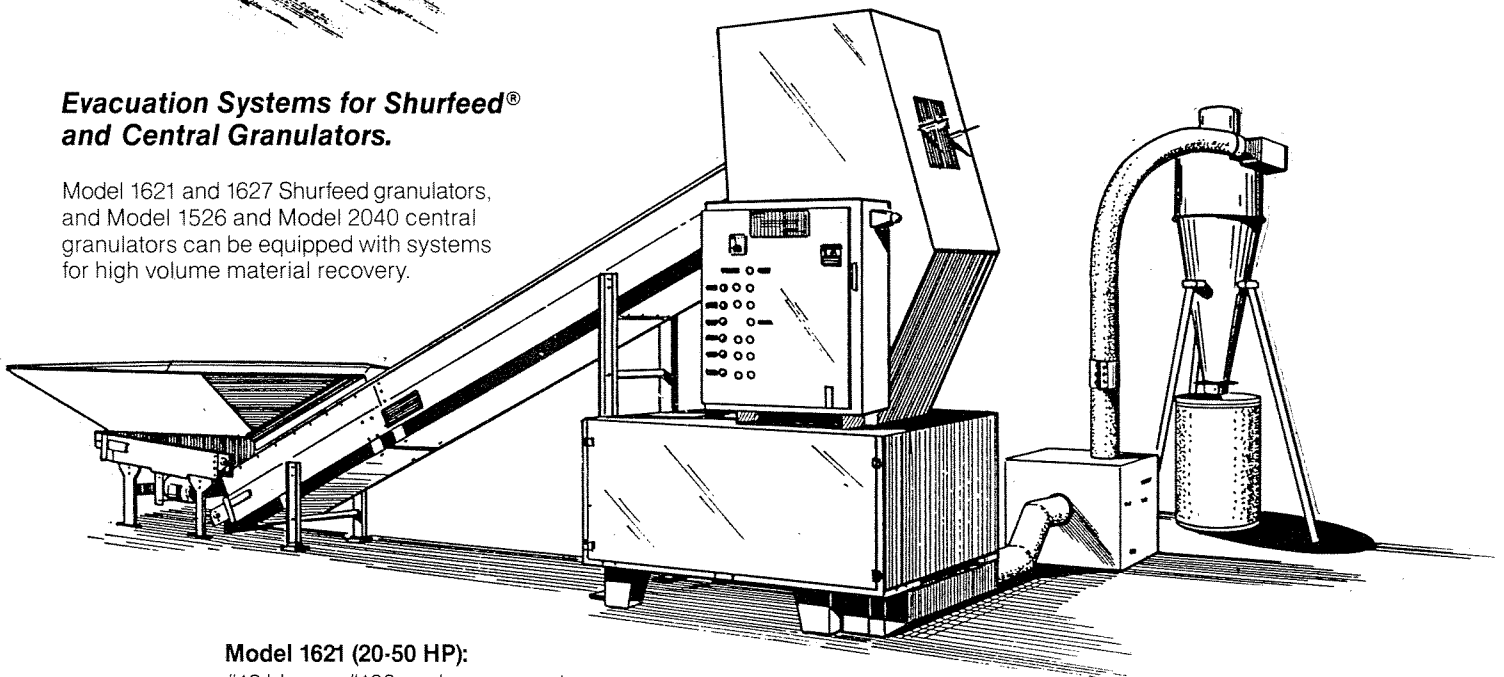

Model 1621 (20-50 HP):
#12 blower, #100 cyclone separator.

Model 1627 (25-75 HP):
#15 blower. #200 cyclone separator.

Model 1526 (50-75 HP):
#15 blower. #200 cyclone separator.

Models 1526 and 2040 (100 HP):
#28 blower, v-belt driven
#10 cyclone separator.

Model 2040 (150 HP):
#29 blower, v-belt driven
#11 cyclone

Systems for Beside The Press Models.

- Model 68:** #9 blower (3/4 HP), #3 cyclone separator.
- Model 912:** #10 blower (1 1/2 HP), #3 cyclone separator.
- Model 1116:** #4 blower (2 HP), #6 cyclone separator.
- Model 1120:** #4 blower (2 HP), #6 cyclone separator.
- Model 1624 Light Duty:** #4 blower (2 HP), #6 cyclone separator.
- Model 1632 Light Duty:** #4 blower (3 HP), #6 cyclone separator.

Larger systems for high throughput requirements are available.

Systems for Special Applications.

Polymer Systems' application engineering service includes custom configurations to meet specific materials handling requirements, such as extended travel, vertical lift, and abrasive materials.



HOSOKAWA POLYMER SYSTEMS
63 Fuller Way, Berlin, CT 06037 • Tel (860) 828-0541 • Fax (860) 829-1313

Specializing in recycling www.hosokawam micron.com
GRANULATORS • SHREDDERS • SYSTEMS