

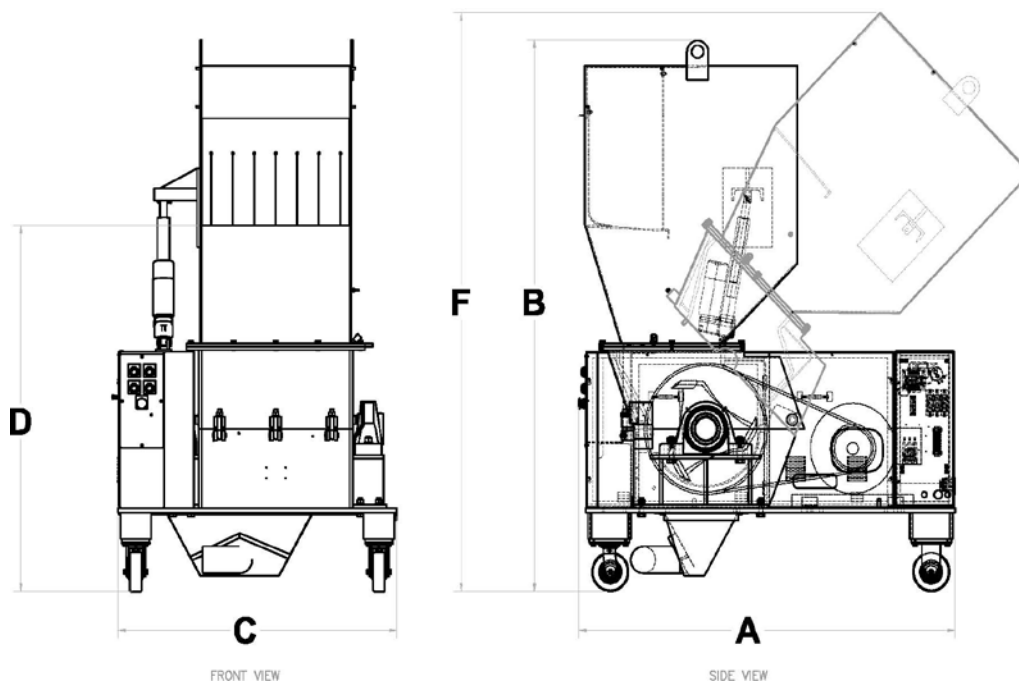

## Large Part Granulators



DIMENSIONS/SPL					
MODEL		A	B	C	D
1620SPL	in.	60	80	41.5	56
	(mm)	(1524)	(2032)	(1054)	(1422)
1624SPL	in.	60	80	45.5	56
	(mm)	(940)	(2032)	(1156)	(1422)
1632SPL	in.	60	80	53.5	56
	(mm)	(1092)	(2032)	(1359)	(1422)

DIMENSIONS/SIL					
MODEL		A	B	C	D
1620SIL	in.	60	80	41.5	56
	(mm)	(1524)	(2032)	(1054)	(1422)
1624SIL	in.	60	80	45.5	56
	(mm)	(940)	(2032)	(1156)	(1422)
1632SIL	in.	60	80	53.5	56
	(mm)	(1092)	(2032)	(1359)	(1422)

SPECIFICATIONS					
MODEL		1620	1624	1632	
Throat Size at Chamber *	in. (mm)	16 x 20 (406 x 508)	16 x 24 (406 x 610)	16 x 32 (406 x 813)	
Screen Area	in. <sup>2</sup> (cm <sup>2</sup> )	470 (3032)	564 (3639)	750 (4839)	
Motor**	HP (kw)	20-30 (15-22)	25-40 (19-30)	30-40 (22-30)	
Cutting Circle (dia.)	in. (mm)	16 (406)	16 (406)	16 (406)	
Rotor Knives	number	3/2	3/2	3/2	
Bed Knives	number	1	1	1	
Weight	SPL	lbs. (kgs)	2000 (910)	2200 (1000)	2500 (1136)
	SIL	lbs. (kgs)	2210 (1005)	2220 (1009)	2530 (1150)
Throughput**	lbs./hr (kgs/hr)	700 (320)	900 (410)	1100 (500)	

\* Measured at entrance to chamber.

\*\* Average figures; throughput varies with different materials, part shapes and screen sizes.