

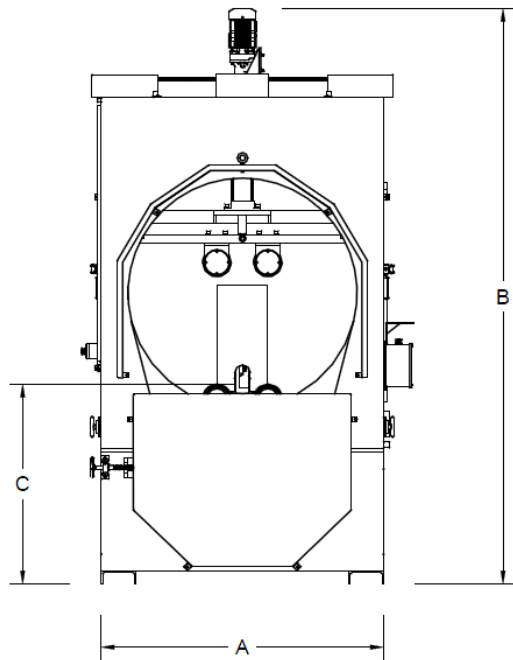

HOSOKAWA POLYMER SYSTEMS

63 Fuller Way, Berlin, CT 06037 · Tel. (860) 828-0541 · Fax (860) 829-1313

PRS – PIPE RECOVERY SYSTEM



FRONT VIEW

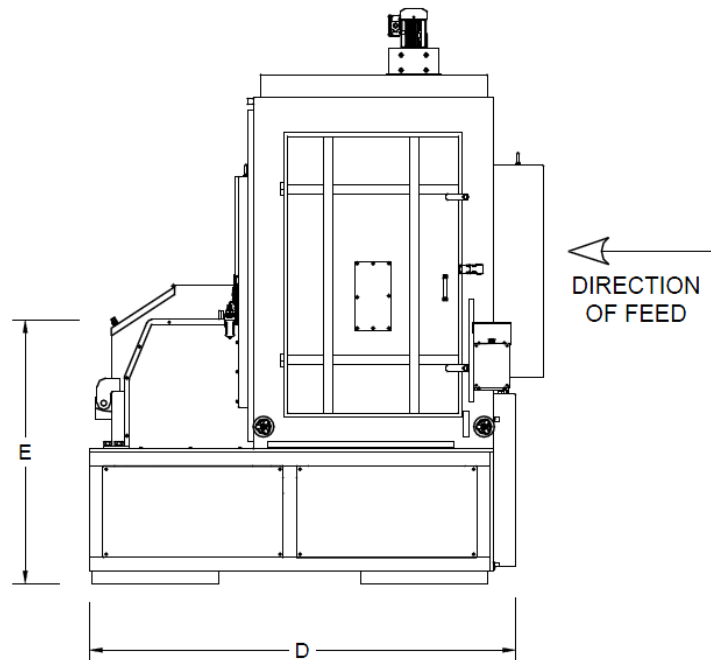

SIDE VIEW

DIMENSIONS						
MODEL		A	B	C	D	E
PRS 630	in.	60	110	52	105	64
PRS 1200	in.	75	140	52	105	64
PRS 1800	in.	98	179	54	105	70

For Pipes up to 40 foot long!

SPECIFICATIONS				
MODEL		630	1200	1800
Pipe Thickness Range*	In.	1/4" – 3"	1/4" – 4"	1/4" – 5"
Pipe Diameter Range OD	In.	4-24	8" – 52"	20" – 72"
Feed Motor	HP	7.5	10	10
Cutter Motor	HP	20-30	25-30	30-40
Rotor Knives	number	5	6	6
Bed Knives	number	1	1	1
Weight	lbs	8500	12000	14000
Throughput**	lbs/hr	1000	2500	4000

**Average figures, throughput varies with different materials and part shapes, based on 2" pressure pipe.