

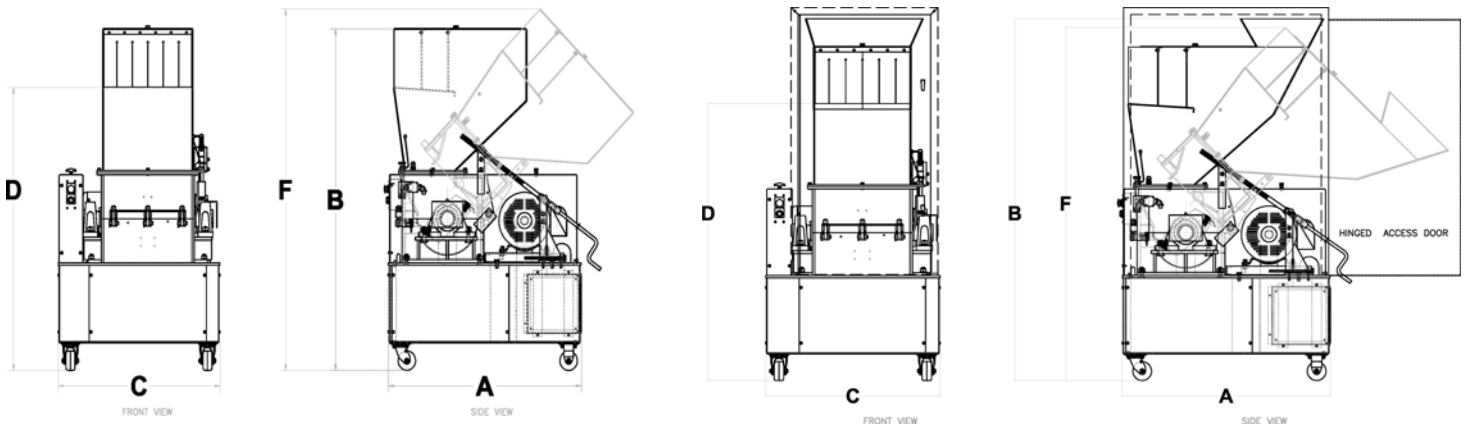

HOSOKAWA POLYMER SYSTEMS

63 Fuller Way, Berlin, CT 06037 · Tel. (860) 828-0541 · Fax (860) 829-1313

Press Side Granulator



DIMENSIONS/SPL MODELS					
MODEL		A	B	C	D
68SPL	in.	31	54.5	21.5	47.5
	(mm)	(787)	(1384)	(546)	(1207)
912SPL	in.	37	62.5	27	53
	(mm)	(940)	(1588)	(686)	(1346)
1116SPL	in.	43	67.5	32	55.5
	(mm)	(1092)	(1715)	(813)	(1410)
1120SPL	in.	43	69	36	57
	(mm)	(1092)	(1753)	(914)	(1448)

DIMENSIONS/SIL MODELS					
MODEL		A	B	C	D
68SIL	in.	31	61	21.5	46.25
	(mm)	(787)	(1549)	(546)	(1175)
912SIL	in.	37	70	27	51
	(mm)	(940)	(1778)	(686)	(1295)
1116SIL	in.	43	76.5	32	55
	(mm)	(1092)	(1943)	(813)	(1397)
1120SIL	in.	43	78	36	56
	(mm)	(1092)	(1981)	(914)	(1422)

SPECIFICATIONS					
MODEL		68	912	1116	1120
Throat Size at Chamber *	in.	6 x 8	9 x 12	11 x 16	11 x 20
	(mm)	(152 x 203)	(229 x 305)	(279 x 406)	(279 x 508)
Screen Area	in. ²	88	190	297	373
	(cm ²)	(568)	(1226)	(1916)	(2406)
Motor**	HP	5	7.5-10	10-25	15-25
	(kw)	(3.7)	(5.6-7.5)	(7.5-18.6)	(11-18.6)
Cutting Circle (dia.)	in.	7	10.3	12.5	12.5
	(mm)	(178)	(262)	(318)	(318)
Rotor Knives	number	2	2/3	2/3	2/3
Bed Knives	number	1	1	1	1
Weight	SPL	lbs.	610	1050	1500
		(kgs)	(277)	(476)	(680)
	SIL	lbs.	800	1200	2200
		(kgs)	(363)	(544)	(816)
Throughput***		lbs./hr	325	400	500
		(kgs/hr)	(147)	(181)	(227)
Bin Capacity		ft ²	1.6	3.6	3.6
		(m ²)	(0.15)	(0.33)	(0.33)

* Measured at entrance to chamber.

** Totally enclosed fan-cooled (TEFC) optional on 15 HP and above.

*** Average figures; throughput varies with different materials, part shapes and screen sizes.

Note: All rotors are open type.

All specification are subject to change without notice.

All production rates & projections are good faith estimates.